

· GH ·

CRANES & COMPONENTS

CARROS ABIERTOS

Para grúas de proceso y grandes capacidades



SE DESARROLLAN COMO ESTÁNDAR EN UNA AMPLIA GAMA DE SELECCIÓN, DESDE 6,3T A 400T

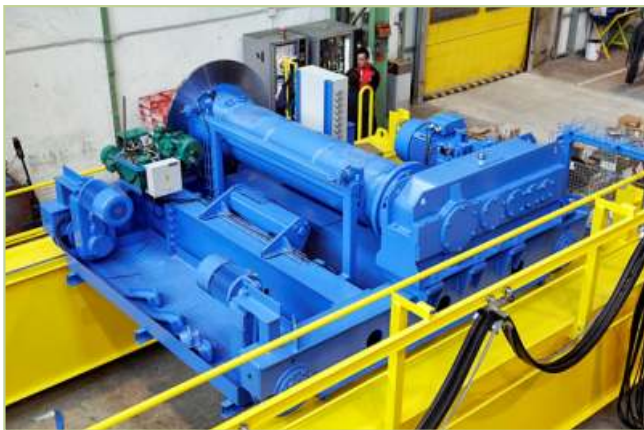

Estos tipos de carros se fabrican bajo demanda para atender unas necesidades, sobre todo de grúas de proceso, con características especiales, bien sean de capacidad, de seguridad o con velocidades u otros requerimientos particulares.

Se les denomina "Carros Abiertos" puesto que todos los elementos de su cadena cinemática se encuentran dispuestos de forma independiente.



¿POR QUÉ CARRO ABIERTO?

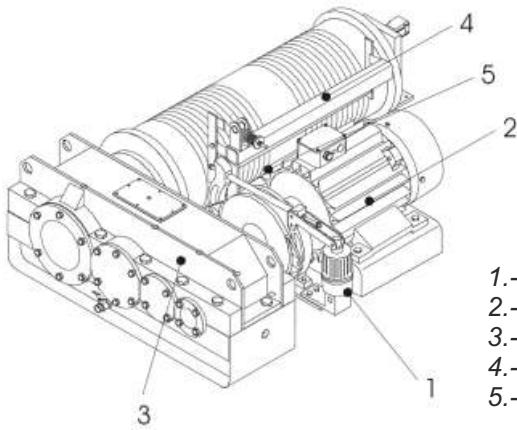

VENTAJAS DEL CARRO ABIERTO:

- De manera general, un carro abierto permite mayor capacidad de elevación y/o mayores velocidades de elevación y/o grupos FEM mas altos, es decir realizan trabajos más severos.
- Posibilidad de trabajar con motores de 3.000, 1.500, 1.000 y 750 rpm. Mayor dimensionamiento del motor.
- Utilización de motores comerciales, pudiendo adecuarse al estándar del cliente. 1 motor, en lugar de aplicaciones con polipasto que necesitan 2 motores para la misma capacidad de elevación y por tanto doblan la probabilidad de fallo del equipo.
- El ataque motor reductor y reductor - tambor están realizados mediante **acoplamientos flexibles intermedios**, absorbiendo las inexactitudes de montaje y las deformaciones por fricción durante la elevación de la carga.
- Ejecución en tiro vertical, sin desplazamiento lateral del gancho durante el movimiento de elevación.
- Mayor accesibilidad para mantenimiento de los diferentes componentes.
- El freno es totalmente exterior, mejorando su accesibilidad y mantenimiento.
- Anticabalgamiento y detector de cable flojo: El anticabalgamiento está formado por un soporte y un mecanismo con resortes unidos con tornillos, cuyo objetivo es evitar que se salga el cable de las ranuras del tambor.



Figura 1
Ejemplo de carro con tambor simple y acoplamiento barrilete.



Figura 2
Ejemplo de carro de doble tambor con acoplamientos en el tambor.

Las inexactitudes de montaje, así como la deformación de las estructuras y desgaste de las partes en funcionamiento, originan enormes fuerzas adicionales, sobre todo en el eje de salida del reductor, que debido a las fuerzas alternativas de flexión producen rotura por fatiga y averías en los rodamientos y ruedas dentadas.

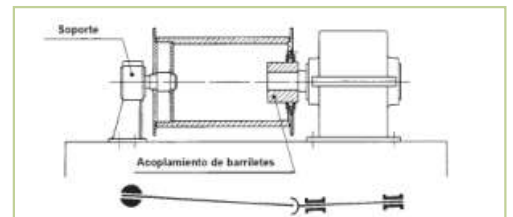
En el montaje indicado en las figuras, adjunta el acoplamiento de barriletes, que se instala entre el reductor y el tambor de cable, ejerce la función de articulación haciendo la unión estáticamente determinada y evitando así la presentación de elevados momentos flectores.

CINEMÁTICAS DE ELEVACIÓN

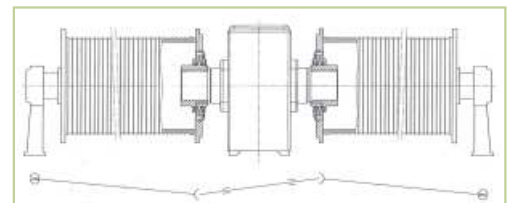
1E - Polipasto GHA12, GHB11, GHD13

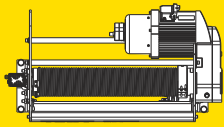

2E - Polipasto GHE, GHF, GHG

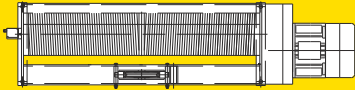

3E - Carro abierto sencillo

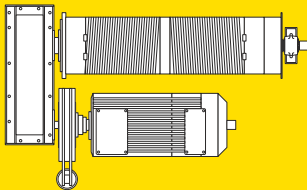

4E - Carro abierto con doble tambor

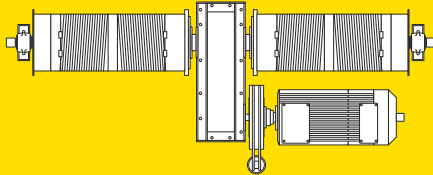

5E - Carro abierto giratorio doble tambor

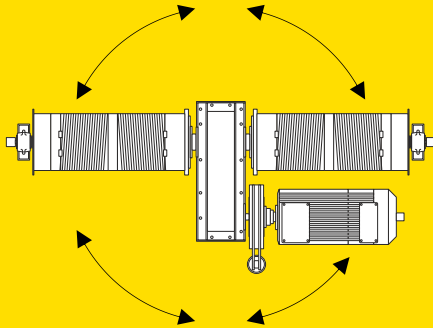

6E - Carro abierto reductor planetario doble tambor freno de seguridad tambor

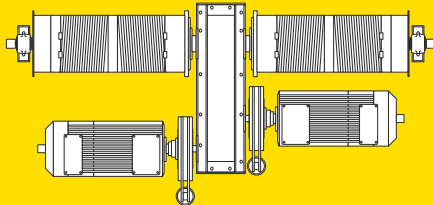

7E - Seguridad redundante, reducciones planetarias doble tambor freno de seguridad tambor

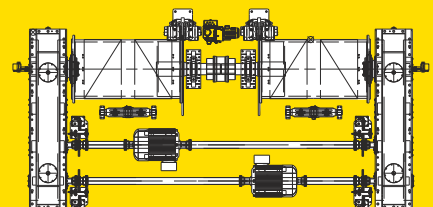

CINEMÁTICAS DE TRASLACIÓN

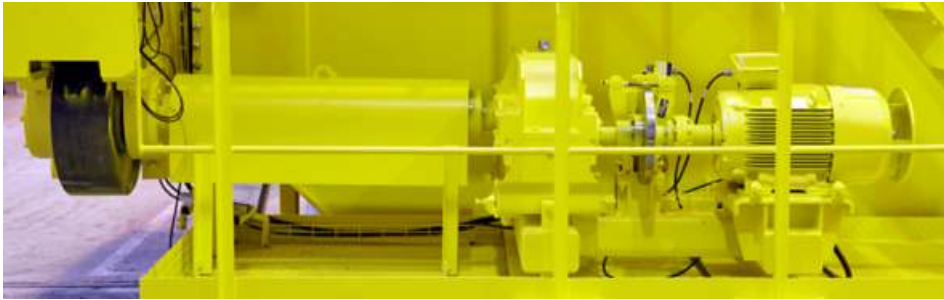

1T - Carro

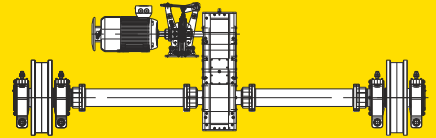

2T - Carro y puente

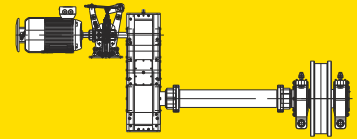

3T - Carro y puente

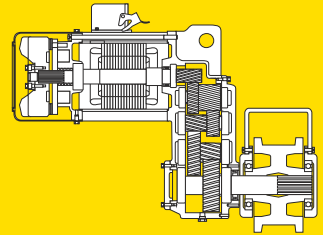

4T - Rodillos horizontales

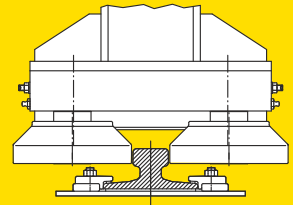

5T - Giro

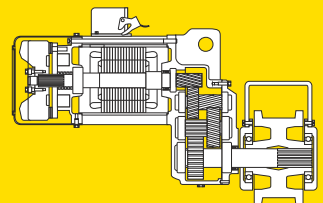

CLASIFICACIÓN FEM

De acuerdo a la clasificación FEM, dos criterios marcan la elección del Grupo de Trabajo:

- El espectro de cargas (k)
- El tiempo medio de utilización diario (T_m)

CLASE DE SERVICIO

Método aproximado

LIGERO - L1

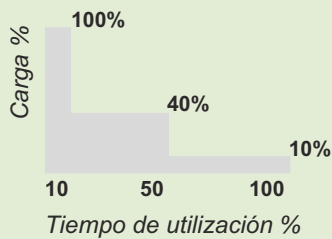

Ocasionalmente a plena carga.
Normalmente cargas reducidas.

MEDIO - L2

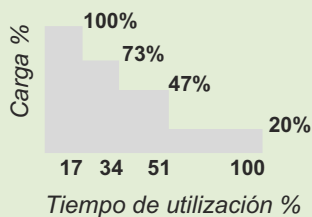

Ocasionalmente a plena carga.
Normalmente cargas medias.

DURO - L3

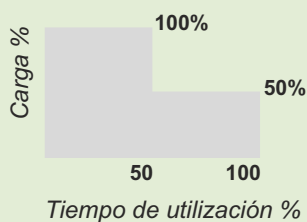

Usualmente plena carga.
Usualmente media carga.

MUY DURO - L4

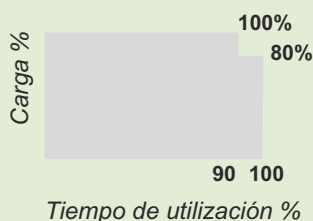

Casi siempre a plena carga.

Espectro de carga	k	T _m			
		4-8	8-16	>16	
L1	Ligero	$k < 0,5$	4-8	8-16	>16
L2	Medio	$0,5 < k < 0,63$	2-4	4-8	8-16 >16
L3	Duro	$0,63 < k < 0,8$	1-2	2-4	4-8 8-16
L4	Muy duro	$0,8 < k < 1$	0,5-1	1-2	2-4 4-8
		FEM	2m	3m	4m 5m
Grupo de mecanismos		ISO	M5	M6	M7 M8
		CMAA	C	D	E F
		GOST	3M	4M	5M 6M

Capacidad de carga	10 t	C
Altura de elevación media	6 m	Lh
Vel. Elevación	5 m/min	V
Nº ciclos/hora	12	Ch
Horas trabajo/día	8 horas	Hd
Estado sollicitación	Medio	

$$T_m = \frac{2 \times L_h \times C_h \times H_d}{60 \times V}$$

$$T_m = \frac{2 \times 6 \times 12 \times 8}{60 \times 5} = 2,56 [\text{horas}]$$

Para un espectro de carga "medio" y un tiempo medio de utilización diaria de 2,56 horas la tabla nos marca un grupo **M5**

El espectro de cargas "k" puede ser determinado de manera exacta como sigue

$$k = \sqrt[3]{\left(\frac{C_1}{C}\right)^3 \cdot \left(\frac{T_1}{T_m}\right) \dots \left(\frac{C_n}{C}\right)^3 \cdot \left(\frac{T_n}{T_m}\right)}$$

Donde (por cada ciclo)

C_i Carga parcial

T_i Tiempo de utilización bajo carga parcial

TABLA DE SELECCIÓN

■ Tablas de selección de grupo de mecanismo en función de la capacidad

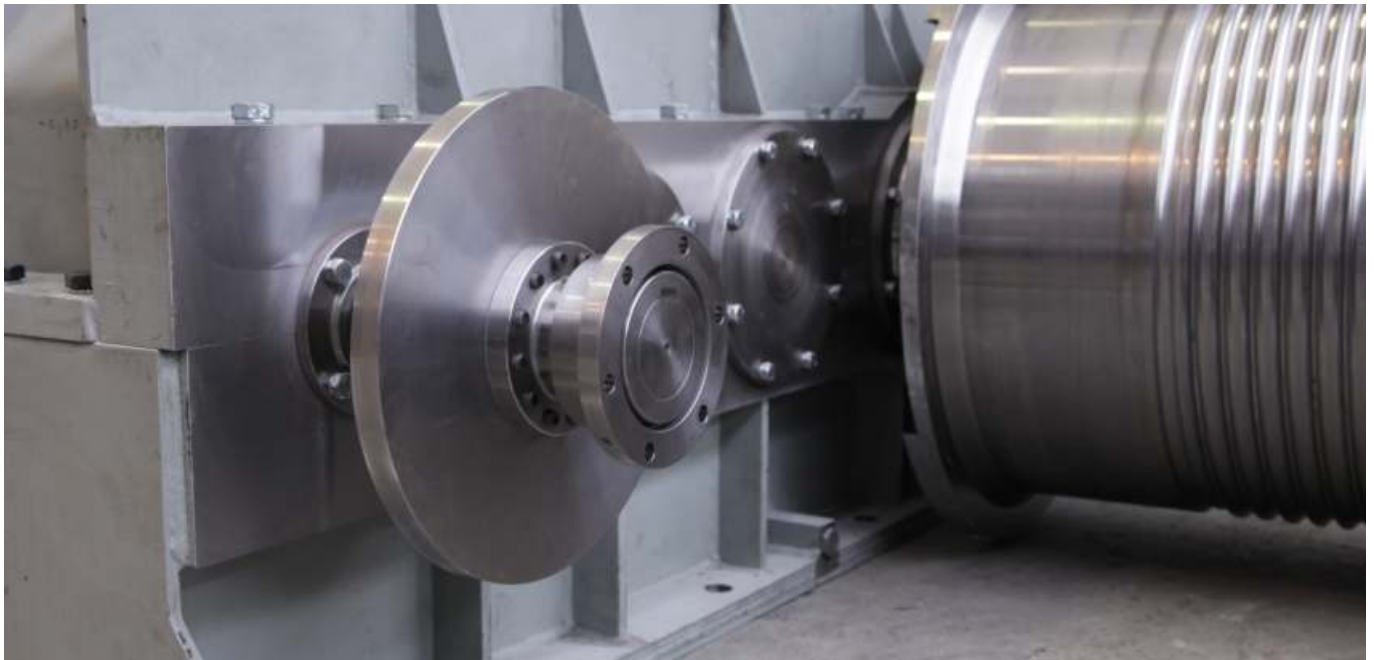

RAMALES	GHF			GHG			GHI			GHJ				GHK			
CARGA(TN)	4/2	8/2	12/2	4/2	8/2	12/2	4/2	8/2	12/2	4/2	8/2	12/2	16/2	4/2	8/2	12/2	16/2
6,3	M8																
8	M8																
10	M8																
12,5	M7	M8		M8													
16	M6	M8		M8													
20	M5	M8		M7			M8										
25		M7	M8	M6	M8		M8										
32		M6	M8	M5	M8		M7			M8							
40		M5	M7	M4	M7	M8	M6	M8		M8							
50			M6		M6	M8	M5	M8		M7				M8			
63			M5		M5	M7		M7	M8	M6	M8			M7			
80					M4	M6		M6	M8	M5	M8			M6			
100						M5		M5	M7		M7	M8		M5	M8		
125									M6		M6	M8		M4	M7		
160									M5		M5	M7	M8		M6	M8	
200												M6	M7		M5	M7	M8
250												M5	M6		M4	M6	M7
320													M5			M5	M6
400																M4	M5

Propuesta de codificación:

025M8I042B3R08
25 tn de capacidad
M8 grupo FEM

I Tipo de reductora
42 4/2 ramales del cable
B motor brida (motor brida=B motor patas=P)

3R n° de trenes de reductora
8 velocidad m/min

TABLA DE SELECCIÓN

■ Tablas de selección para carros abiertos con ramales a 8/2.

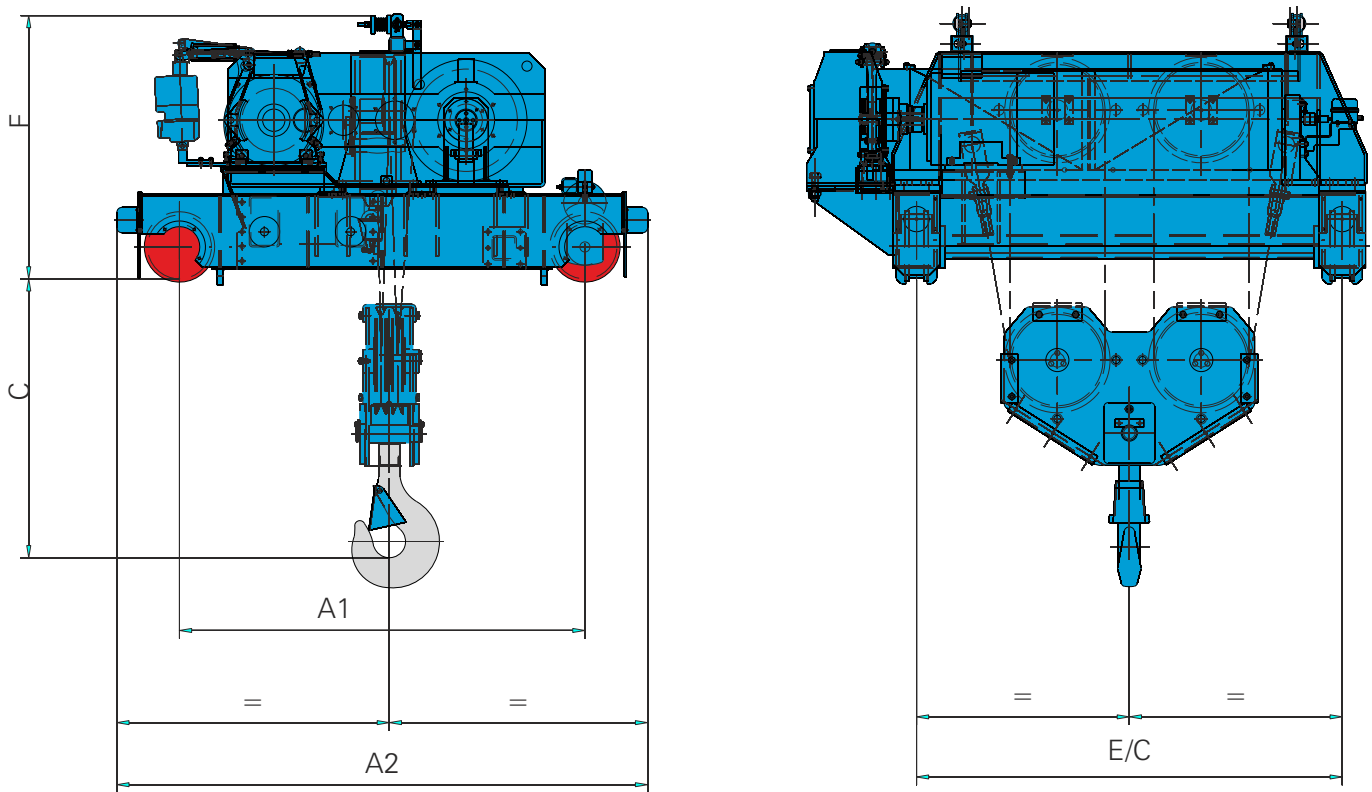

Modelo	Capacidad	Clasificación		Alturas			Velocidades					Dimensiones				E/c			Pesos		
		Ramales	t	FEM	ISO	H1	H2	H3	V1	V2	V3	V4	V5	F	C	A1	A2	H1	H2	H3	H1
GHF	12,5	5 m	M8	10	15	20	3	4	6	8	10	1165	1065	2000	2565	1800	2400	3000	3400	3700	4300
	16	5 m	M8																		
	20	5 m	M8																		
	25	4 m	M7																		
	32	3 m	M6																		
40	2 m	M5																			
GHG	25	5 m	M8	10	15	20	3	4	6	8	1355	1255	2000	2625	2000	2500	3000	5900	6200	6500	
	32	5 m	M8																		
	40	4 m	M7																		
	50	3 m	M6																		
	63	2 m	M5																		
80	1 Am	M4	1450	1115	2805																
GHI	40	5 m	M8	10	15	20	3	4	6	8	1545	1555	2400	3205	2240	2500	3150	13400	14000	14600	
	50	5 m	M8																		
	63	4 m	M7																		
	80	3 m	M6																		
100	2 m	M5	1455	1415																	
GHJ	63	5 m	M8	10	15	20	3	4	6	1680	2150	2600	3600	2240	2800	3500	18700	19800	20800		
	80	5 m	M8																		
	100	4 m	M7																		
	125	3 m	M6																		
	160	2 m	M5																		
1960																					
GHK	100	5m	M8	10	15	20	3	4	6	2250	1860	3500	4532	2800	3300	3800	24000	26000	28000		
	125	4m	M7																		
	160	3m	M6																		
	200	2m	M5																		
	250	1Am	M4																		
1760	1660	1560	1460																		

TABLA DE SELECCIÓN

■ Tablas de selección para carros abiertos con ramales a 12/2 y 16/2.

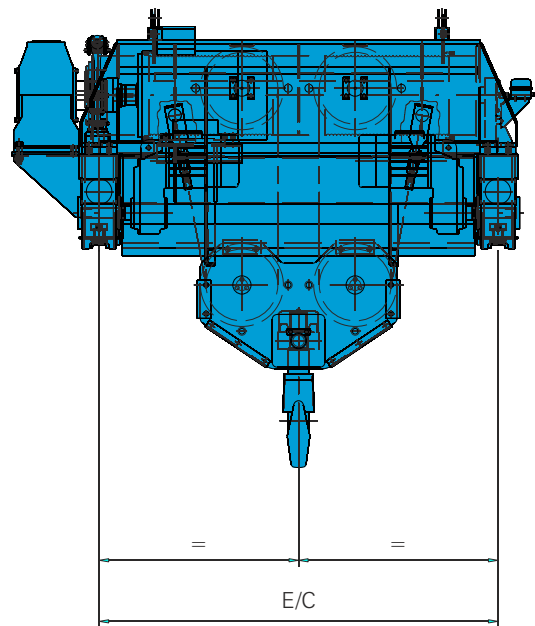
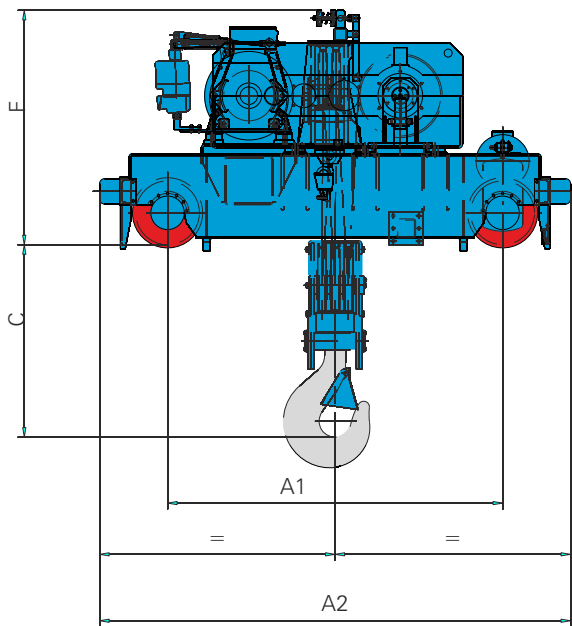

Modelo	Capacidad	Clasificación		Alturas			Velocidades					Dimensiones				E/c			Pesos		
Ramales	t	FEM	ISO	H1	H2	H3	V1	V2	V3	V4	V5	F	C	A1	A2	H1	H2	H3	H1	H2	H3
GHF	25	5 m	M8	10	15	20	2	2,7	4	5,4	8	1350	1100	2000	2625	2500	3150	4000	4100	5500	5900
	32	5 m	M8																		
12/2	40	4 m	M7																		
	50	3 m	M6																		
	63	2 m	M5																		
GHG	40	5 m	M8	10	15	20	2	2,7	4	5,4		1450	1290	2000	2805	2500	3150	4000	7700	9000	10500
	50	5 m	M8																		
	12/2	63	4 m										M7								
		80	3 m										M6								
		100	2 m										M5								
GHI	63	5 m	M8	10	15	20	2	2,7	4	5,4		1545	1875	2400	3205	2600	3500	4200	14900	16500	17300
	80	5 m	M8																		
	12/2	100	4 m									M7									
		125	3 m									M6									
		160	2 m									M5									
GHJ	100	5 m	M8	10	15	20	1	2	2,5	4		1745	2375	2600	3740	2800	3500	4200	21600	23800	25000
	125	5 m	M8																		
	12/2	160	4 m										M7								
		200	3 m										M6								
		250	2 m										M5								
GHK	160	5m	M8	10	15	20	1	2	2,5	4		2350	1885	3500	4532	3300	4050	4800	26000	29000	31000
	200	4m	M7																		
	12/2	250	3m										M6								
		320	2m										M5								
		400	1Am										M4								

Modelo	Capacidad	Clasificación		Alturas			Velocidades					Dimensiones				E/c			Pesos		
Ramales	t	FEM	ISO	H1	H2	H3	V1	V2	V3	V4	V5	F	C	A1	A2	H1	H2	H3	H1	H2	H3
GHJ	160	5m	M8	10	15	20	1,5	2	2,5	3		2450	2270	3500	4532	3300	4050	4800	26000	29000	31000
	200	4m	M8										2170								
	250	3m	M7										2070								
	320	2m	M6										3350								
GHK	200	5m	M8	10	15	20	1,5	2	2,5	3		2450	2270	3500	4532	3300	4050	4800	26000	29000	31000
	250	4m	M8										2170								
	320	3m	M7										2070								
	400	2m	M6										3350								

CARRO ABIERTO GIRATORIO

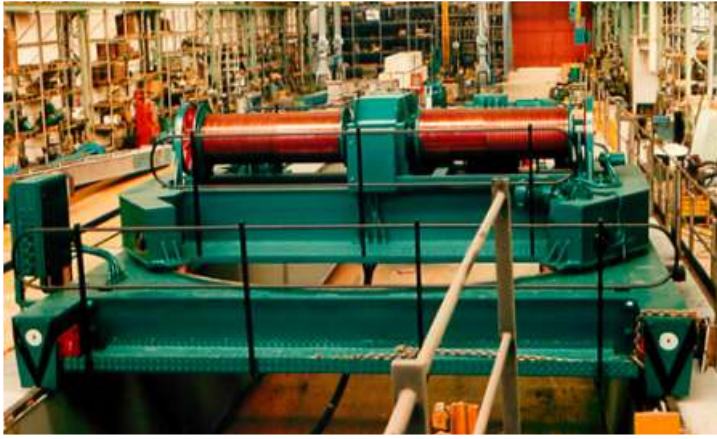

Opción interesante para el manejo de traviesas, ya sean para manipular palanquilla, productos largos, bobinas de papel o cazo de chatarra o metal líquido.



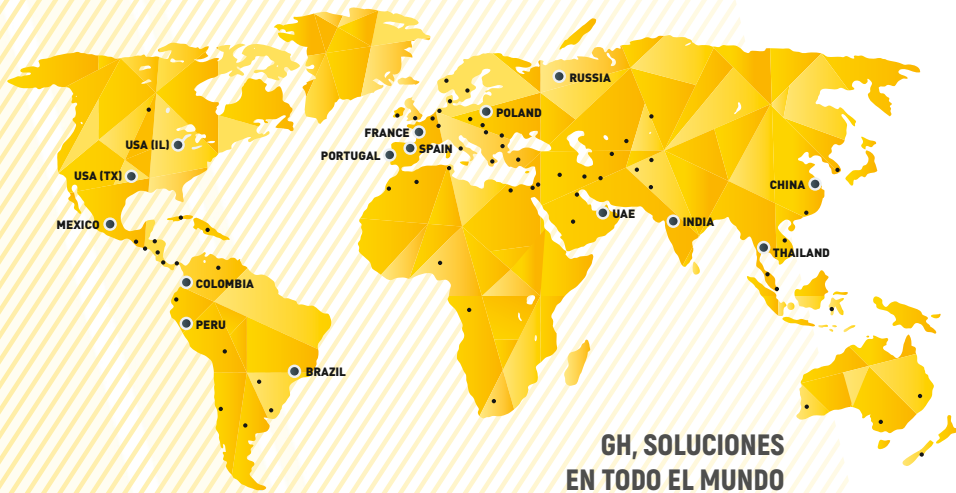

GH, SOLUCIONES
EN TODO EL MUNDO

Presencia en

+73 PAISES
EN 5 CONTINENTES

+ 112.000
grúas instaladas

+ 750

EN EL **TOP 5** FABRICANTES
DE GRÚAS
DEL MUNDO

GH, España sede central

-GH-

www.ghcranes.com



Beasain

OFICINAS CENTRALES
T: +34 943 805 660
ghcranes@ghcranes.com



Olaberría

GH GLOBAL SERVICE
T: +34 902 205 100
globalservice@ghcranes.com



Alsasua

MECANIZADO
T: +34 948 467 625



Bakaiku

FABRICACIÓN GRÚAS
T: +34 948 562 611



Jaén

REPUESTOS
T: +34 902 205 100

GH, filiales en el mundo



Brasil

Cabreúva

GH DO BRASIL IND. E COM. LTDA.
T: +52 44 22 77 55 03
ghdobrasil@ghdobrasil.com.br



China

Shanghai

GH (SHANGHAI)
LIFTING EQUIPMENT CO., LTD.
T: +86 21 5988 7676
ghchina@ghsa.com



Colombia

Bogotá

GH COLOMBIA SAS
T: +57 1 750 4427
yezpeleta@ghsa.com



Francia

Couëron

GH FRANCE SA
T: +33(0) 240 861 212
ghfrance@ghsa.com



India

Pune

GH CRANES INDIA PVT. LTD.
T: +91 89561 35444
ghindia@ghsa.com



México

Querretaro

GRÚAS GH MEXICO SA DE CV
T: +66 (0) 2327 9399
M: +66 (0) 8 4660 1365
ghmexico@ghsa.com.mx



Perú

Lima

GH PERÚ S.A.C.
T: +51 987816231
gferradas@ghsa.com



Polonia

Kłobuck

GH CRANES SP. Z O.O.
T: +48 34 359 73 17
intertech@ghsa.pl



Portugal

Mamede do Coronado

GH PORTUGAL
T: +351 229 821 688
geral@ghsa.com



Rusia

Moscú

GH RUSSIA
T: +7 (495) 745 69 26
ghrussia@ghsa.com



Tailandia

Chonburi

LGH Cranes
T: +66 (0) 2327 9399
M: +66 (0) 8 4660 1365
ghthailand@ghsa.com



UAE

Dubai

GH Cranes Arabia FZCO
Office no. 517, 5th Floor, Jafza
Building 16, Jebel Ali Free Zone.
P.O Box Number - 263594
T: +971 4 8810773
gharabia@ghcranes.com



EEUU

Illinois

GH CRANES USA
T: (815) 277 5328
ghcranesusa@ghsa.com



EEUU

Texas

F&G CRANES
T: (972) 563 8333
info@fg-ind.com

**Lifting
your
world.**